

Bogusława Lachowska¹
The John Paul Catholic University of Lublin

Conflict styles and outcomes in parent-adolescent relationship and adolescent family satisfaction

Streszczenie

W artykule określono znaczenie konfliktów w relacji między adolescentami i ich rodzicami dla satysfakcji adolescentów z życia rodzinnego. Stwierdzono pozytywny związek satysfakcji z dążeniem rodziców do kompromisu oraz negatywny – z agresją rodziców. Satysfakcja adolescentów jest tym większa, im częściej konflikty z ojcem kończą się poprawą relacji (intymność) a im rzadziej konflikty z matką kończą się ich eskalacją i frustracją. Potwierdzono istotną rolę zachowania każdego z rodziców w sytuacji konfliktu z adolescentem, jednakże najsilniejszym predyktorem satysfakcji adolescentów jest dążenie ojca do kompromisu. Zgodnie z hipotezą emocjonalnego dystansowania się Steinberga, wraz z wiekiem adolescenta zmniejsza się jego satysfakcja z rodziny a coraz częściej dochodzi do eskalacji konfliktów i narastania frustracji w relacji z matką.

Słowa kluczowe

adolescencja, satysfakcja z życia rodziny, style rozwiązywania konfliktu, rezultaty konfliktów

Abstract

In my article I identified the meaning of conflict in parent-adolescent relationship for adolescent family satisfaction. It was found that family satisfaction is positively related to seeking compromise by the parents, as well as being negatively related to parental aggression. Adolescent satisfaction is higher when conflicts with the father more often result in improving their relationship (intimacy), and when conflicts with the mother end less frequently with escalation and frustration. A significant parental behavioral role in conflict with the adolescent was confirmed; however, the strongest predictor of adolescent family satisfaction is in seeking compromise by the father. In accordance with Steinberg's emotional distancing hypothesis, with the adolescent's age family satisfaction was found to decrease, and conflicts escalated and frustration in mother-adolescent relationship increased.

Keywords

adolescence, family satisfaction, conflict style, conflict outcome

¹ Bogusława Lachowska, Institute of Psychology, Faculty of Social Sciences, The John Paul Catholic University of Lublin, Al. Raławickie 14, 20–950 Lublin; lachow@kul.lublin.pl

Introduction

Subjective well-being created an attractive studies area in modern psychology. Great interest in these topics is undoubtedly related to the developments in positive psychology in recent years (Seligman & Csikszentmihalyi, 2000). Studies on subjective well-being of children and adolescents take an important place in this field. For instance, Diener and colleagues (Diener, Suh, Lucas & Smith, 1999) analysed demographic factors and resources influencing subjective well-being. Their results point to a large role played by life events, both major and daily events (McCullough, Huebner, & Laughlin, 2000). Since conflicts with parents are a big part of their everyday life, can be resolved in different ways, and have different outcomes, a question arises: what do such conflicts mean for adolescent well-being?

In psychology the research on well-being is conducted in two major philosophical traditions: hedonic and eudemonic (Czapiński, 2015; Trzebińska, 2008), the former being used in my study. In this light subjective well-being (SWB) is defined as “a broad category of phenomena that includes people’s emotional responses, domain satisfactions, and global judgments of life satisfaction” (Diener et al., 1999). Diener and colleagues (Diener, Suh, Oishi, 1997) propose that well-being reflects satisfaction with life, pleasant affect, and low unpleasant affect levels. Satisfaction with life is the cognitive subjective well-being component and can be assessed independently from the context. What is evaluated then, is how individuals are generally satisfied with their life. However, Diener and collaborators (1997) propose that “global satisfaction can be distinguished as satisfaction with the various domains of life”, which can result in life satisfaction being – depending on the researcher’s aim – limited to a specific context. In adults it is usually career, romantic relationship, and for youth this specific context is school and family. Diener and colleagues (1997) believe that studying well-being concentrated on a narrow context allows for a better understanding of specific conditions influencing it. My study focuses on one aspect of the hedonistically approached subjective well-being: satisfaction. The focus, however, is put on family – a very important area for adolescent life. Family satisfaction is defined as “the degree to which family members feel happy and fulfilled with each other” (Olson, 2016). Analyzing the processes related to SWB, Diener (1984) distinguishes bottom-up and top-down processes. Bottom-up processes determine external factors which impact SWB, namely, various situations, external events, and demographics. Studies show that even though personality traits and affect dispositions are good predictors of long-term subjective well-being, situational variables, such daily events or interactions with other people explain short-term well-

being (DeNeve & Cooper, 1998). Among situational factors, the relationship with parents is especially central for an adolescent's well-being. Effective parenthood, next to relationships with peers, is considered an essential variable in a youth's development and their life satisfaction. Analyzing many studies, Mupinga, Garrison and Pierce (2002) propose that parents should adjust their expectations and discipline to their child's capabilities so that they can develop social responsibility without curbing their independence and individuality. On the basis of 19 interviews with non-clinical adolescents, Joronen and Astedt-Kurki (2005) identified six elements significant in their life satisfaction: emotionally warm atmosphere, comfortable home, familial involvement, sense of personal significance in the family, possibilities for external relations and open communication. Factors contributing to low well-being were ill-being or death of a family member excessive dependency, and familial hostility. Their data show that good communication and lack of hostility in family relations are important factors in adolescent life satisfaction.

Families with an adolescent child experience a transformation of relationships, so how both parties behave is crucial in this process (Grotevant & Cooper, 1985). Scalars stress that for these renegotiated relationships to have positive outcomes, conflicts are indispensable (Collins, 1990). Hence, communication and ability to resolve conflicts are significant factors bringing positive changes in family relations with an adolescent child.

From the social psychology perspective, conflict is defined as perceived incompatibilities of the views, wishes, and desires that are held by each party in the conflict (De Dreu, Havinck, & VanVianen, 1999, as cited in Bell & Song, 2005). Conflict is often a relational phenomenon arising between two independent parties engaged in a common activity (Bell & Song, 2005). These two characteristics, simultaneous competition and cooperation make conflict a complex situation. Experts agree that conflict is neither positive nor negative in nature, but is rather an unavoidable consequence of change and growth (Crum, 1987, as cited in Corcoran & Mallinckrodt, 2000). It can be assumed that conflict, being a transformational reflection and renegotiation of relations, will eventually appear between parents and adolescents. How a particular disagreement is resolved may lead to different outcomes. Fisher, Ury and Patron (1991, as cited in Corcoran & Mallinckrodt, 2000) believe that conflict has negative consequences when one or both parties adopt a "win-lose" approach. In such a case disputes are rarely resolved and new disagreements are more likely to arise. In turn, conflicts are resolved effectively when each party cooperates in finding solutions which will fulfil everyone's needs. Therefore, the crucial element of effective dispute resolution is willingness to work together (Fisher, Ury, & Patron, 1991, as cited in Corcoran & Mallinckrodt, 2000).

Effective communication is generally perceived as a fundamental characteristic of a well-functioning family. It helps in defining one's position in the family, developing sensitivity to needs and feelings of others, supports individuality and connectedness as well as independence, autonomy, which facilitates individuation (Jackson, Bistra, Oostera, & Bosma 1998). Adolescents growing up in families with good communication skills are more satisfied with their family as well as their lives in general, have higher self-esteem, feel healthier and are happier (Jackson et al., 1998). Their results show that the way a family copes with conflict affects the well-being of children, spouses and the family as a whole (Cox & Paley, 1997; Cummings & Davies, 2002).

A conflict's important aspects are its style and outcomes. Conflict style is defined as "a patterned response to conflict involving the repeated use of the same tactics to resolve disputes" (Hocker & Wilmot, 1991, as cited in Corcoran & Mallinckrodt, 2000). It describes how an individual usually reacts to the other person in a dispute. In turn, conflict outcomes are described as its results, which are caused by how both parties behave. There are two conflict style dimensions: compromise and aggression. Seeking compromise includes behaviors such as listening to the partner, reasoning, putting forward arguments, striving for a settlement, and caring for the partner. On other hand, aggression is understood as anger, sarcasm and shouting (Honest et al., 1997). Conflict outcomes which are most often studied in research are escalation, frustration and intimacy (Honest et al., 1997). Escalation is experienced when conflict behaviors lead to more inclusive issues in the argument and in using what has been said against the other person. Frustration is understood as ending up feeling hurt, annoyed, and thinking that the argument was a waste of time. In turn, intimacy involves better understanding, feeling sorry. In some cases, the parties accept that it is possible to have different views (Honest et al., 1997).

My aim in the present article is to determine what conflict styles and outcomes mean in a parent-adolescent relationship, separately for the mother and the father and for the adolescent's family satisfaction. In order to meet my goal, conflict styles and outcomes as perceived by adolescents were analyzed.

Honest and colleagues (1997) quote the results of studies which found that mothers and fathers exert different types of influence on the adolescent. The relationship with the mother is more complex and is more often characterized by partnership, equality and intimacy, in comparison to the relations with the father. Adolescents state that they talk to their mother more than to the father, and view her as more understanding and accepting. In contrast, the father is experienced as showing authority, passing judgment, and being less willing to talk about personal issues and feelings (Youniss & Smolar, 1985, as cited in Jackson et al., 1998). Goeke and Cummings (2007) state that "fathers may contribute more to some

child development aspects, or in different ways, than mothers” (p. 221). Results of studies in attachment theory show that the safe attachment style with both the father and the mother has positive consequences socially and cognitively; however, attachment style outcomes with the father are independent of the the attachment style effects with the mother. When the father is engaged in having a relationship with the child in the early stages of his or her development, a safe attachment style is formed, which is in turn related to other positive outcomes (Pleck, 2007). In turn, Bronfenbrenner’s Ecological Theory (1986, as cited in Pleck, 2007) proposes that the father functions as a microsystem partner and interacting with him promotes development. However, he is not an additional partner in the child’s microsystem; together, they create a separate system, different from the one formed with the mother. Based on the abovementioned discussion, in my study the adolescent relationships with both parents were analyzed. It is expected that the conflict style displayed separately by the mother and the father as well as conflict outcomes will be related to family satisfaction in adolescents (Fig. 1):

H 1. Father and mother aggression as well as father and mother conflict escalation are negatively related to adolescent family satisfaction.

H 2. Father and mother compromise as well as father and mother intimacy are positively related to adolescent family satisfaction.

It is believed that independence and a tendency to emphasize differences is typical for adolescence (Cooper & Awers-Lopez, 1985, as cited in Honess et al., 1997). At this time young people extend their social circles, express themselves in new ways and become more autonomous, which may generate tension and create conflicts with parents (Jackson et al., 1998). In accordance with Steinberg’s distancing hypothesis (1988), emotional distance is created between the teenager and their parents. Thus, it is proposed that (Fig. 1):

H 3. With age adolescents experience more frustration and escalation, and less intimacy, as conflict outcomes with the father and mother.

Figure 1. Theoretical model of correlations between parental conflict styles and conflict outcomes, adolescent age and their family satisfaction.

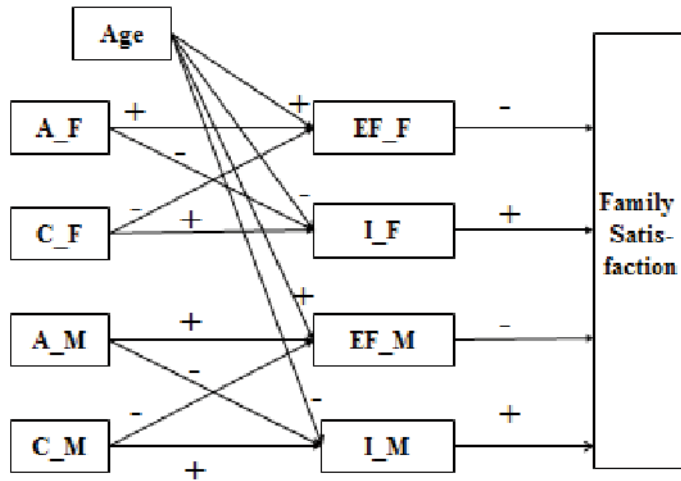

EF_F – Escalation and frustration outcome (father); I_F – Intimacy outcome (father); EF_M – Escalation and frustration outcome (mother); I_M – Intimacy outcome (mother); A_F – Aggression (father); C_F – Compromise (father); A_M – Aggression (mother); C_M – Compromise (mother)

Materials and Methods

The study participants were 177 students aged 11 to 17 ($M = 13.72$; $SD = 1.06$), including 89 boys. All the participants come from families with two parents present in the family life.

To measure conflict styles and outcomes the Polish version (Lachowska, 2010) of Disagreement Questionnaires by Honess and colleagues (1997) was used. They include measuring conflict styles (aggression and compromise) and conflict outcomes (escalation, frustration and intimacy) which are important because they inflict changes in the adolescent's environment (Honess et al., 1997). The adolescent is required to describe his or her father's and mother's behavior: "How well does each of the following statements describe YOUR FATHER/YOUR MOTHER/ when you and he/she/ disagree about something which is important to both of you?" Answers are provided on a four-point scale: 1 – not at all, 2 – not too well, 3 – fairly well, 4 – very well. In the aggression scale the maximum value is 28, the minimum is seven, in the compromise scale the possible results range from five to 20. A higher score indicates a stronger intensity of a given parental behavioral type.

Both scales are homogeneous, which is indicated by internal reliability coefficients for aggression $\alpha = 0.88$, and for compromise $\alpha = 0.80$ (Lachowska, 2010).

Concerning questionnaires examining conflict outcomes, the adolescent is required to think about disagreement outcomes with father or mother: „Different things can happen when two people have a serious disagreement. How often does each of these things happen when YOU and your FATHER/or MOTHER/disagree about something which is important to both of you?” Answers are provided on a five-point scale: 1 – never, 2 – almost never, 3 – once in a while, 4 – fairly often, 5 – very often. In escalation and frustration the possible scores range from 11 to 55, in intimacy the score ranges from sixties to 30. A higher score indicates a stronger effect. Both scales are homogeneous, as indexed by *alpha* coefficients for escalation and frustration $\alpha = 0.87$, for intimacy $\alpha = 0.77$ (Lachowska, 2010).

Family satisfaction was assessed using the Polish version (Lachowska, 2008) of a 10-item scale developed by Olson (2016). The family satisfaction scale is based on a 14-item scale developed by Olson and Wilson (1982). The scale was designed to assess satisfaction with various family aspects including family closeness, flexibility and communication. The participants state how satisfied they are with different family life aspects for example, the degree of closeness between family members. Subjects rated their experiences on a five-point scale ranging from 1- very dissatisfied, to 5- extremely satisfied. The possible score ranges from 10 to 50, where a higher score indicates higher satisfaction with family functioning. The original and Polish scales have high internal reliability indicators (Cronbach’s *alpha*), which is $\alpha = 0.92$ for the original, and $\alpha = 0.95$ for the Polish version.

Results

Table 1 presents descriptive statistics, and Table 2 shows Pearson’s *r* coefficients between the variables.

Table 1. Descriptive statistics among the variables

| Variable | M | SD | Wynik minimalny | Wynik maksymalny | Skośność | Kurtoza |
|---------------------|------|------|-----------------|------------------|----------|---------|
| Aggression (father) | 1.96 | 0.74 | 1.00 | 3.86 | 0.393 | -0.827 |
| Compromise (father) | 2.77 | 0.71 | 1.00 | 4.00 | -0.231 | -0.537 |
| Aggression (mother) | 2.18 | 0.82 | 1.00 | 4.00 | 0.114 | -1.032 |
| Compromise (mother) | 2.71 | 0.71 | 1.00 | 4.00 | -0.133 | -0.548 |

| Variable | M | SD | Wynik minimalny | Wynik maksymalny | Skośność | Kurtoza |
|---|-------|------|-----------------|------------------|----------|---------|
| Escalation and frustration outcome (father) | 2.48 | 0.88 | 1.00 | 4.45 | 0.194 | -0.733 |
| Intimacy outcome (father) | 2.93 | 0.83 | 1.00 | 4.83 | -0.065 | -0.277 |
| Escalation and frustration outcome (mother) | 2.49 | 0.89 | 1.00 | 4.82 | 0.230 | -0.667 |
| Intimacy outcome (mother) | 2.88 | 0.81 | 1.00 | 4.83 | 0.057 | -0.288 |
| Family Satisfaction | 37.06 | 7.79 | 15 | 50 | -0.507 | 0.030 |
| Age | 13.72 | 1.06 | 11 | 17 | 0.147 | -0.351 |

M – mean; SD – standard deviation; * $p < 0.05$; ** $p < 0.01$; *** $p < 0.001$.

Table 2. Correlations between family satisfaction, conflict scales and age of the adolescents

| Variables | 1. | 2. | 3. | 4. | 5. | 6. | 7. | 8. | 9. |
|--|----------|--------|---------|---------|---------|---------|---------|---------|------|
| 1. Family satisfaction | – | | | | | | | | |
| 2. Age | -0.23** | – | | | | | | | |
| 3. Aggression (father) | -0.09 | -0.07 | – | | | | | | |
| 4. Compromise (father) | 0.40*** | 0.03 | -0.11 | – | | | | | |
| 5. Aggression (mother) | -0.06 | 0.04 | 0.38*** | -0.04 | – | | | | |
| 6. Compromise (mother) | 0.25*** | -0.08 | -0.12 | 0.31*** | -0.06 | – | | | |
| 7. Escalation and frustration outcome (father) | -0.15* | 0.12 | 0.58*** | -0.19** | 0.37*** | -0.08 | – | | |
| 8. Intimacy outcome (father) | 0.27*** | 0.03 | 0.01 | 0.38*** | 0.10 | 0.34*** | 0.19** | – | |
| 9. Escalation and frustration outcome (mother) | -0.25*** | 0.23** | 0.33*** | 0.04 | 0.57*** | -0.09 | 0.55*** | 0.14 | – |
| 10. Intimacy outcome (mother) | 0.20** | 0.04 | 0.04 | 0.16* | -0.03 | 0.40*** | 0.16* | 0.45*** | 0.03 |

* $p < 0.05$; ** $p < 0.01$; *** $p < 0.001$.

Structural Equation Modeling (SEM) using AMOS for SPSS 22 was used (Arbuckle, 2007). Structural Equation Modeling allows one to specify and estimate models

of linear relationships between the variables. In the present study, explorative and confirmative factor analyses were carried out, which means that the model which had been created using theoretical knowledge (Fig. 1) was tested and subsequently modified (Perek-Białas & Górnica, 2008). The model was fitted by eliminating paths with insignificant loadings and introducing new paths according to modification indices (Kline, 2005). The obtained fit indices of the final model (Fig. 2) are [$\chi^2(15) = 9.78; p = 0.83; CMIN/df = 0.65; GFI = 0.989; AGFI = 0.965, RMSEA < 0.001 (LO < 0.001; HI = 0.43; PCLOSE = 0.97), NFI = 0.978; CFI = 1.00; RFI = 0.934]$ and show that the model fits variance and covariance matrices, which allows one to conclude that it is a useful reproduction of the reality.

Figure 2. Standardized path coefficients for age of the adolescents, parental conflict styles and outcomes and family satisfaction.

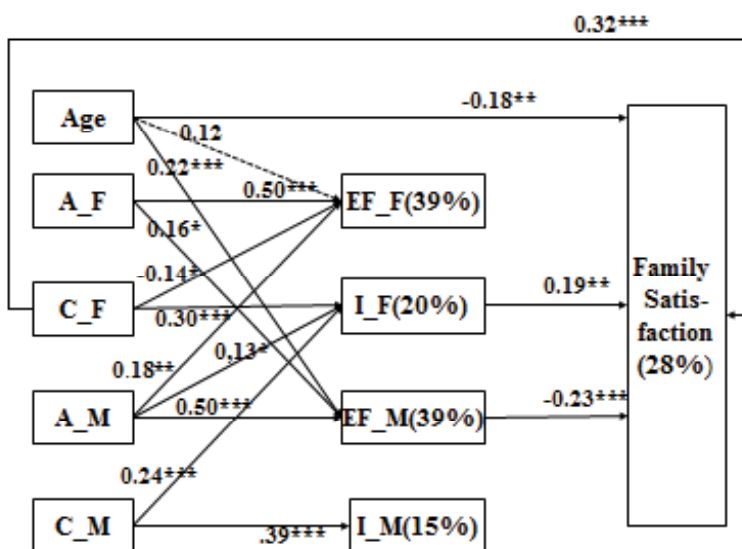

EF_F – Escalation and frustration outcome (father); I_F – Intimacy outcome (father); EF_M – Escalation and frustration outcome (mother); I_M – Intimacy outcome (mother); A_F – Aggression (father); C_F – Compromise (father); A_M – Aggression (mother); C_M – Compromise (mother)

The analyses show that father and mother conflict styles are significantly related to adolescent family satisfaction. It was found that the strongest predictor of family satisfaction is when the father compromises (standardized total effect was 0.37, Table 3). It was shown that the father’s compromise influences adolescent family satisfaction mainly directly (0.32), and partially indirectly through intimacy with the father, which was brought about by the compromising behaviors. The effect of other parental conflict styles is weaker and indirect: it is caused by conflict outcomes. The mother compromise

is related to higher family satisfaction in the adolescent (0.05), as long as such behavior improves the adolescent-father relationship and increases intimacy between them.

In turn, father aggression is related to lower family satisfaction in adolescents when it causes conflict escalation and frustration in the relationship with the mother (0.04). Mother aggression is related to lower family satisfaction if it leads to conflict escalation and increasing adolescent frustration (-0.09). Among the two conflict outcomes, only father intimacy and mother escalation and frustration are significantly related to the adolescent family satisfaction. In other words, adolescent family satisfaction is higher when conflicts with the father more frequently result in intimacy, and conflicts with the mother less frequently end with escalation and frustration. Furthermore, a relatively strong predictor of family satisfaction is adolescent age. As the teenagers get older, their family satisfaction decreases (-0.23), but this effect is mainly direct (-0.18); it is indirect to a lesser extent, through mother escalation and frustration (standardized regression coefficient -0.05). All the variables explain together 28% of family satisfaction.

Table 3. Standardized direct and total effects

| | β | 95% Confidence Interval | | Two tailed significance |
|---|---------|-------------------------|--------------|-------------------------|
| | | Lower bounds | Upper bounds | |
| Standardized direct effects | | | | |
| Age → Family Satisfaction | -0.18 | -0.312 | -0.055 | 0.007 |
| Age → Escalation and frustration outcome (father) | 0.12 | -0.003 | 0.234 | 0.054 |
| Age → Escalation and frustration outcome (mother) | 0.22 | 0.116 | 0.324 | 0.004 |
| Aggression(father) → Escalation and frustration outcome (father) | 0.50 | 0.369 | 0.628 | 0.002 |
| Aggression(father) → Escalation and frustration outcome (mother) | 0.16 | 0.011 | 0.294 | 0.029 |
| Compromise (father) → Escalation and frustration outcome (father) | -0.14 | -0.265 | -0.007 | 0.039 |
| Compromise (father) → Intimacy outcome (father) | 0.30 | 0.116 | 0.463 | 0.007 |
| Aggression(mother) → Escalation and frustration outcome (father) | 0.18 | 0.048 | 0.319 | 0.009 |
| Aggression(mother) → Intimacy outcome (father) | 0.13 | 0.002 | 0.258 | 0.047 |
| Aggression(mother) → Escalation and frustration outcome (mother) | 0.50 | 0.353 | 0.642 | 0.007 |

| | β | 95% Confidence Interval | | Two tailed significance |
|---|---------|-------------------------|--------------|-------------------------|
| | | Lower bounds | Upper bounds | |
| Compromise (mother) → Intimacy outcome (father) | 0.24 | 0.102 | 0.387 | 0.003 |
| Compromise (mother) → Intimacy outcome (mother) | 0.39 | 0.243 | 0.519 | 0.005 |
| Intimacy outcome (father) → Family Satisfaction | 0.19 | 0.021 | 0.363 | 0.024 |
| Escalation and frustration outcome (mother) → Family Satisfaction | -0.23 | -0.361 | -0.078 | 0.009 |
| Compromise (father) → Family Satisfaction | 0.32 | 0.149 | 0.456 | 0.006 |
| Standardized total effects | | | | |
| Age → Family Satisfaction | -0.23 | -0.358 | -0.104 | 0.004 |
| Aggression(father) → Family Satisfaction | -0.04 | -0.102 | -0.007 | 0.015 |
| Compromise(father) → Family Satisfaction | 0,37 | 0,226 | 0,496 | 0,004 |
| Aggression(mother) → Family Satisfaction | -0.09 | -0.165 | -0.006 | 0.029 |
| Compromise(mother) → Family Satisfaction | 0.05 | 0.011 | 0.121 | 0.008 |

Discussion

The aim of my study was to analyze father and mother behavior in a conflict situation with the adolescent, in relation to adolescent family satisfaction. According to the expectations, parental aggression was found to decrease family satisfaction (Hypothesis 1), and compromise was found to increase it (Hypothesis 2), for the relations with both the father and the mother. Moreover, results were expected showing that intimacy (Hypothesis 2) and avoiding escalated frustration (Hypothesis 1) encourages adolescent family satisfaction. Intimacy was found to be significant in conflict outcome with the father, and the lack of escalation and frustration as conflict outcome with the mother were also anticipated. What we found especially important was that the results point to the central role of the father in forming adolescent family satisfaction. As it turns out, father compromise and seeking conflict resolution which improves the adolescent-father relationship have the biggest impact on family satisfaction. In this case father behavior is related to adolescent satisfaction mainly directly: increasing family satisfaction, as well as indirectly: through intimacy outcome, even though this correlation is much weaker. The present study showed the father as an integral member of the family. The analyses allowed us to determine the meaning of father behavior, next to mother behavior, in forming adolescent

well-being. The results led to the conclusion that a good relationship between father and children is a crucial, but often neglected, resource in adolescent development. This finding enabled us to confirm past hypotheses (e.g. Honess et al., 1997) on the different, but equally important role of each parent in child development.

Our study confirmed Steinberg's emotional distancing hypothesis (1988). We show that with adolescent age this growing emotional distance is expressed in decreased family satisfaction and escalation of conflict with the mother, which results in a rising frustration. It needs to be stressed that distancing was reported only in the relationship with the mother. It is maybe linked to the specificity of this relation which is more intimate than the one with the father (Honess et al., 1997; Jackson et al., 1998). The result showing that emotional distancing is related to conflict escalation and frustration, but is not related to intimacy (which makes Hypothesis 3 partially confirmed) also seems to be important. It can be concluded that even though emotional distancing is expressed in lower family satisfaction and rising conflict and frustration with the mother, it does not mean that intimacy in the relationship with both parents is reduced.

It is necessary to point out potential limitations of the study. Firstly, since the analyses were correlational in nature, the longitudinal design of subsequent research is called-for to verify the results. Secondly, using self-report measures can be viewed as a limitation as well. However, taking into consideration the nature of the variables, which refer to how an individual feels about their family life and how they perceive parental behavior, it seems that using self-reports was a necessity and was not possible to replace them with observation. Another limitation is the restricted use of the results, which is caused by the fact that the participants were not a representative sample of the population.

References

- Bell C., Song F. (2005). Emotions in the conflict process: an application of the cognitive appraisal model of emotions to conflict management. *The International Journal of Conflict Management*, 16 (1), 30–54.
- Corcoran K.O., Mallinckrodt B. (2000). Adult Attachment, Self-Efficacy, Perspective Taking, and Conflict Resolution. *Journal of Counseling and Development*, 78, 473–483.
- Cox M. J., Paley P. (1997). Families as systems. *Annual Review of Psychology*, 48(1), 243–67.
- Cummings E. M., Davies P. T. (2002). Effects of marital conflict on children: recent advances and emerging themes in process-oriented research. *Journal of Child Psychology and Psychiatry*, 43(1), 31–63.

- Czapiński, J. (2015). *Psychologia pozytywna. Nauka o szczęściu, zdrowiu, sile i cnotach człowieka*. Warszawa: Wydawnictwo PWN.
- DeNeve, K. M., Cooper, H. (1998). The happy personality: a meta-analysis of 137 personality traits and subjective well-being. *Psychological Bulletin*, 124, 197–229.
- Diener, E., Suh, E., S. (1997). Recent findings on subjective well-being. *Indian Journal of Clinical Psychology*, 24(1), 25–41.
- Diener, E. (1984). Subjective well-being. *Psychological Bulletin*, 95, 542–575.
- Diener, E. (1994). Assessing subjective well-being: Progress and opportunities. *Social Indicators Research*, 31, 103–157.
- Diener, E., Suh, E., M., Lucas, R., E., and Smith, H., L. (1999). Subjective well-being: three decades of progress. *Psychological Bulletin*, 125(2), 276–302.
- Goeke-Morey, M. C., Cummings, E. M. (2007). Impact of father involvement: a closer look at indirect effects models involving marriage and child adjustment. *Applied Development Science*, 11, (4), 221–225.
- Grotevant, H. D., Cooper, C. R. (1985). Patterns of interaction in family relationships and the development of identity exploration in adolescence. *Child Development*, 56(2), 415–428.
- Honess, T. M., Charman, E. A., Zani B., Cicognani, E., Xerri M. L., Jackson A. E., Bosma, H. A. (1997). Conflict between parents and adolescents: variation by family constitution. *British Journal of Developmental Psychology*, 15, 367–385.
- Jackson S., Bistra J., Oostra L., Bosma H. (1998). Adolescent's Perceptions of Communication with Parents Relative to Specific Aspects of Relationships with parents and personal development. *Journal of Adolescence*, 21, 305–322.
- Joronen, K., Astedt-Kurki, P. (2005). Familial contribution to adolescent subjective well-being. *International Journal of Nursing Practice*, 11 (3), 125–133.
- Kline, R. B. (2005). *Principles and practice of Structural Equation Modeling*. New York, London: The Guilford Press.
- Lachowska, B. (2008). Model Kołowy Systemu Małżeńskiego i Rodzinnego w opracowaniu D. H. Olsona i współpracowników oraz narzędzia jego pomiaru. *Roczniki Teologiczne. Nauki o Rodzinie*. LV(10), 189–207.
- Lachowska, B. (2010). Style rozwiązywania konfliktów i ich efekty w relacji między rodzicami i adolescentami – prezentacja narzędzi pomiaru. W: D. Borecka-Biernat

- (red.). *Sytuacje konfliktu w środowisku rodzinnym, szkolnym i rówieśniczym. Jak sobie radzą z nimi dzieci i młodzież?* Warszawa: Difin SA. 180–206.
- McCullough, G., Huebner, E. S., Laughlin, J. E. (2000). Life events, self-concept, and adolescents' positive subjective well-being. *Psychology in the Schools*, 37, 281–290.
- Mupinga E.E., Garrison M.E.B., Pierce S.H. (2002). An Exploratory Study of the Relationships Between Family Functioning and Parenting Styles: The Perceptions of Mothers of Young Grade School Children. *Family and Consumer Sciences Research Journal*, 31(1), 112–129.
- Olson, D. H. (2016). Family Satisfaction Scale (FSS). www.facesiv.com/secure, retrieved on 11.01.2016
- Olson, D.H., Wilson, M. (1982) Family Satisfaction. In: D.H. Olson and colleagues. *Families: What Makes Them Work*. Newbury Park, CA: Sage Publishing.
- Perek-Białas, J., Górniak, J. (2008). *Wprowadzenie do modelowania równań strukturalnych z programem SPSS AMOS*. Materiały kursowe – do użytku wewnętrznego. Kraków: AGH, SPSS.
- Pleck, J. H. (2007). Why could father involvement benefit children? Theoretical perspectives. *Applied developmental Science*, 11 (4), 196–202.
- Seligman, M., E., P., Csikszentmihalyi M. (2000). Positive psychology: an introduction. *American Psychologist*, 55(1), 5–14.
- Steinberg, L. D. (1988). Reciprocal relations between parent-child distance and pubertal maturation. *Developmental Psychology*, 24, 122–128.
- Trzebińska E. (2008). *Psychologia pozytywna*. [Positive psychology] Warszawa: Wydawnictwa Akademickie i Profesjonalne spółka z o.o.